



Dimensions

Height	8 000mm
Width	4 000mm
Length	2 250mm
Feed Opening	1 800mm x 1 050mm

Bale Dimensions

Height	750mm
Width	1 100mm
Length	1 050mm - 1 450mm
Wire Tie System	Accent (USA) 470

Performance

Motor	60HP (45kw)
Oil Reservoir	3000L 3000L
Throughput (TPH) <small>(Max. Plastic Bottle)</small>	15-20 18-30
Machine Weight	28T 28T
Main Cylinder	D250
Ejector Cylinder	D224
Max. Force	120 Tons

Features

- High Force horizontal baler
- Low power consumption - auto sleep mode
- Intuitive controls
- Multiple product settings
- Touchscreen operator interface
- Low noise
- Replaceable shear knife and wear plates
- Hopper access door
- Continuous feed

Optional Extras

- PET Perforator
- Dejamming Cylinders
- Feed conveyor
- Power Pack upgrade
- Hardox upgrades
- Custom hopper



Dimensions and technical information without obligation. Subject to change.

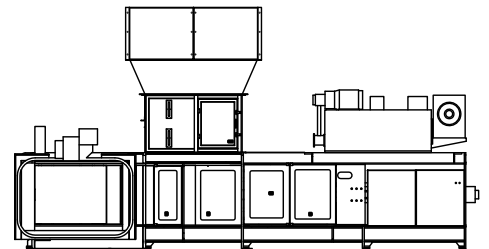
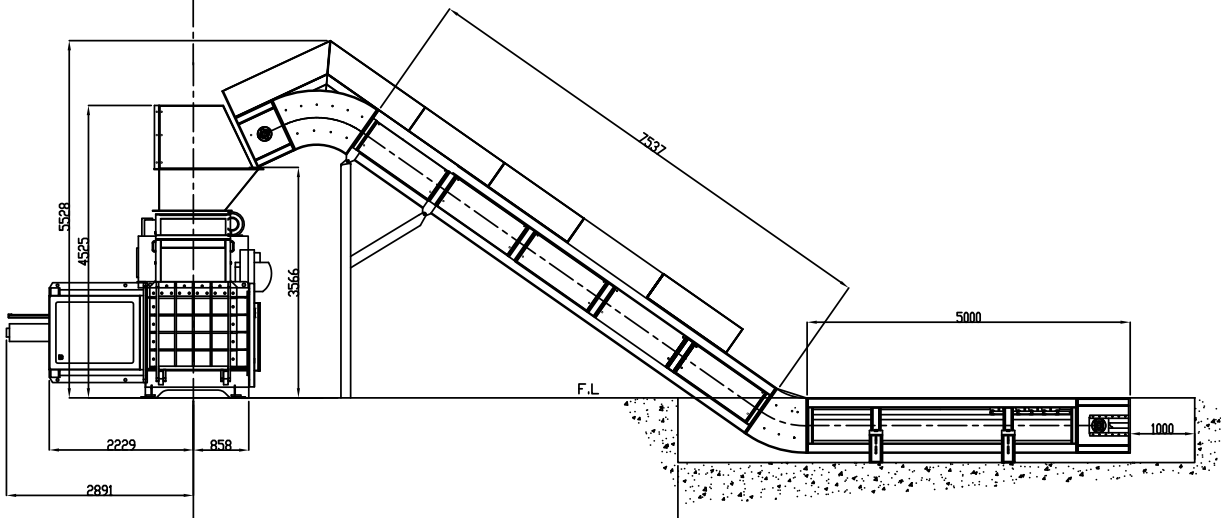
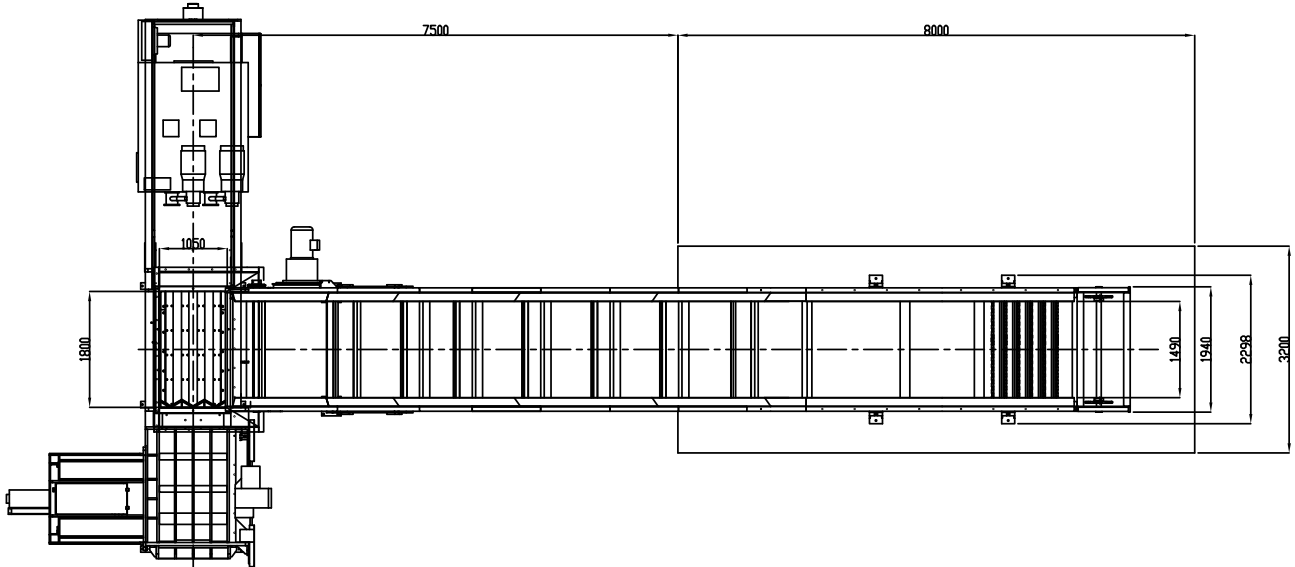

Size Comparison



Pressing Force
Up to 120 Ton



Motor
60 HP / 40 HP*2



Waste Types
Cardboard, Paper,
Plastics, MSW

