



## Dimensions

Height	1 875 mm
Width	2 564 mm
Length	2 825 mm
Approx Weight	5 000 kg
Motor Power	55 kW
Main Shaft Speed	74 r/min
Rotor-knive	66 +4 pcs

## Cutting Chamber

Length	1 410 mm
Width	1 200 mm

[More product info on our website >>](#)

## Features

- Pusher ram introducing the material to the cutting rotor
- Hardened steel rotor knives
- Integrated shock absorbers
- Material sizing screens
- Built in hydraulic power pack
- Suitable for Cardboard, Plastic, Paper, Timber and Cans
- Auto Reverse Protection
- Easy Maintenance
- Reliable & Durable Construction
- Generous Loading Aperture

## Optional Extras

- Additional Vertical Force Feeding Ram
- Film Rotor
- Hard Material Rotor, Film Rotor
- Custom Hopper Designs
- In-Feed and Out Feed Conveyors
- Elevated work and loading platforms



Dimensions and technical information without obligation. Subject to change.

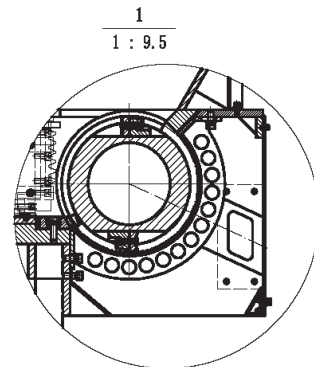
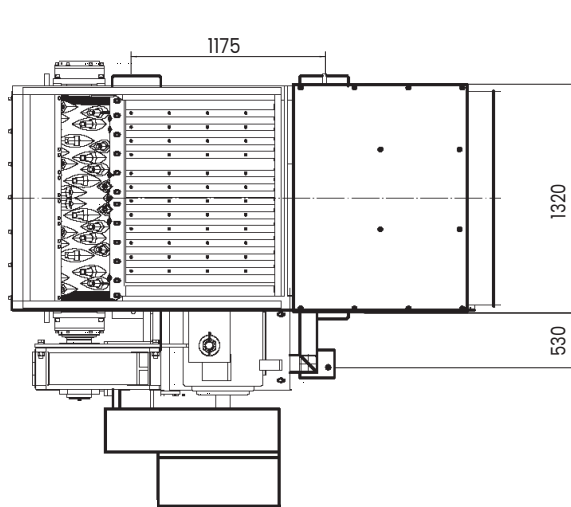
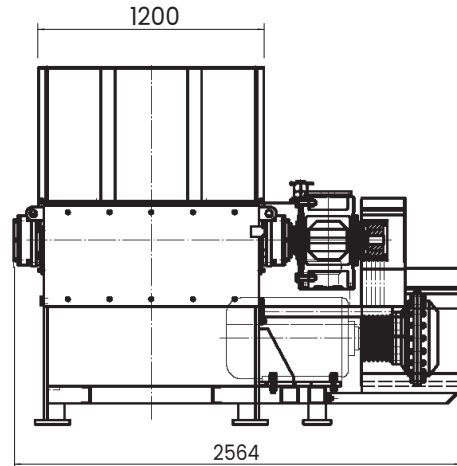
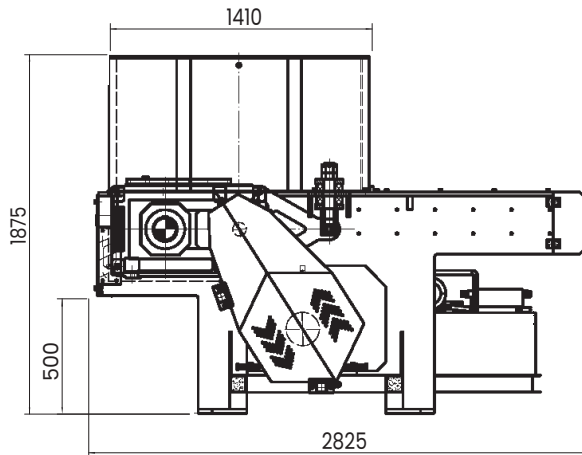

Size Comparison



**Shaft Speed**  
74 (r/min)



**Rotor Knife**  
66 +4 (pcs)



**Motor**  
55 kW



**Waste Types**  
Suitable for Cardboard,  
Plastic, Paper, Timber  
and Cans

