



Dimensions

Height	2 580 mm
Width	1 198 mm
Depth	927 mm
Weight	600 kg
Transportation Height	1 800 mm

Loading Aperture Sizes

Height	1 202 mm
Width	823 mm
Depth	816 mm

Performance

Power Supply	415V 3 Phase
Motor	11 kW 32A
Pressing Force	Up to 24T
Noise Level	74 dB
Cycle Time	57 Seconds

Features

- Compaction ratio of 6:1
- Fully enclosed compaction chamber ensures maximum level of safety
- 30L oil collection tank with tap connection for easy drainage

Optional Extras

- Adaptor head to compact inside 205L drum
- Galvanised finish
- Insert for crushing oil filters
- Smaller bale head inside to compact a 200L steel drum



Dimensions and technical information without obligation. Subject to change.

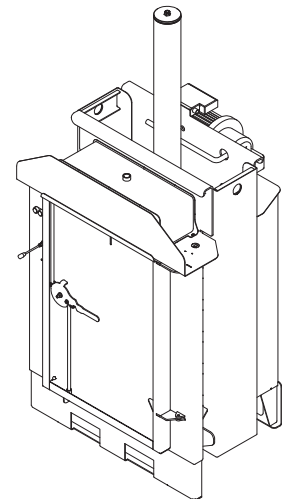
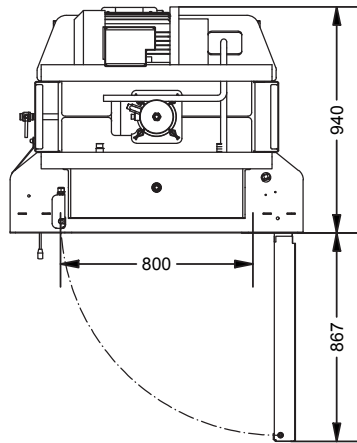
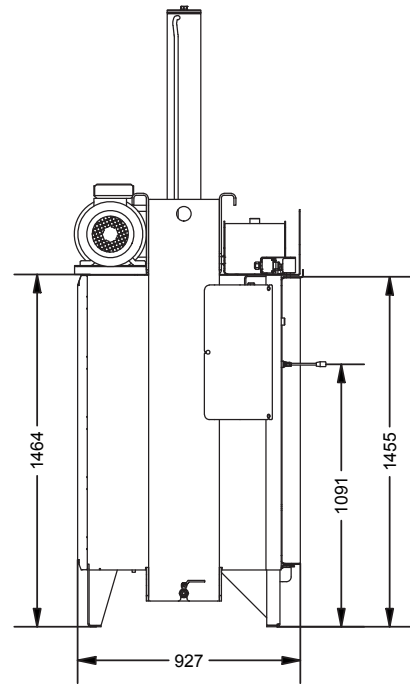
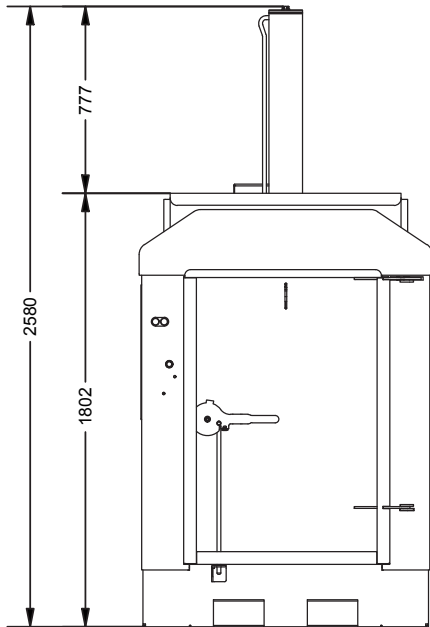

Size Comparison



Compaction Ratio
Up to 6:1



Pressing Force
Up to 24 Ton



Motor
11kW



Waste Types
Metal Drums

