



### Baler Dimensions

Height	2 895 mm
Width	1 755 mm
Depth	1 190 mm
Weight	985 kg
Transportation Height	2 214 mm
Power Supply	240V 1 Phase
Motor	2.2kw 15A
Pressing Force	Up to 16T
Noise Level	74dB
Cycle Time	34s

### Bale Dimensions

Height	1 000 mm
Width	1 194 mm
Depth	800 mm
Weight	Up to 250kg

### Loading Aperture Sizes

Height	678 mm
Width	1 194 mm

### Baler Features

- Retaining claws to prevent spring back of material
- Fully automatic bale ejector, simplifies bale removal
- PLC Panel with automatic compaction cycles
- Bale full indicator
- Dual cylinders for even compaction
- 2 year warranty

### Optional Extras

- Galvanised finish
- Sliding top door for easy loading of material
- 3-Phase 415V power supply



Dimensions and technical information without obligation. Subject to change.

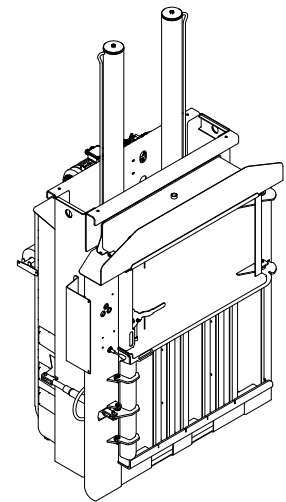
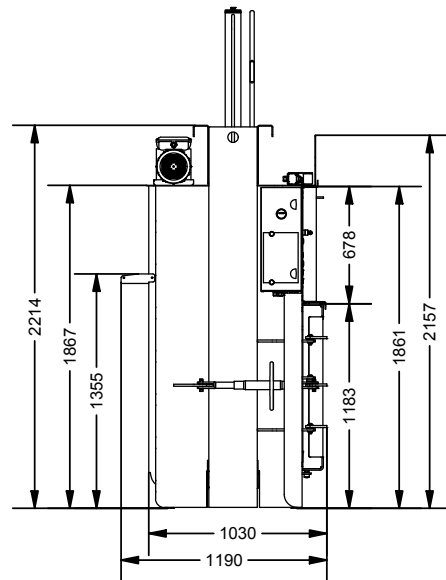
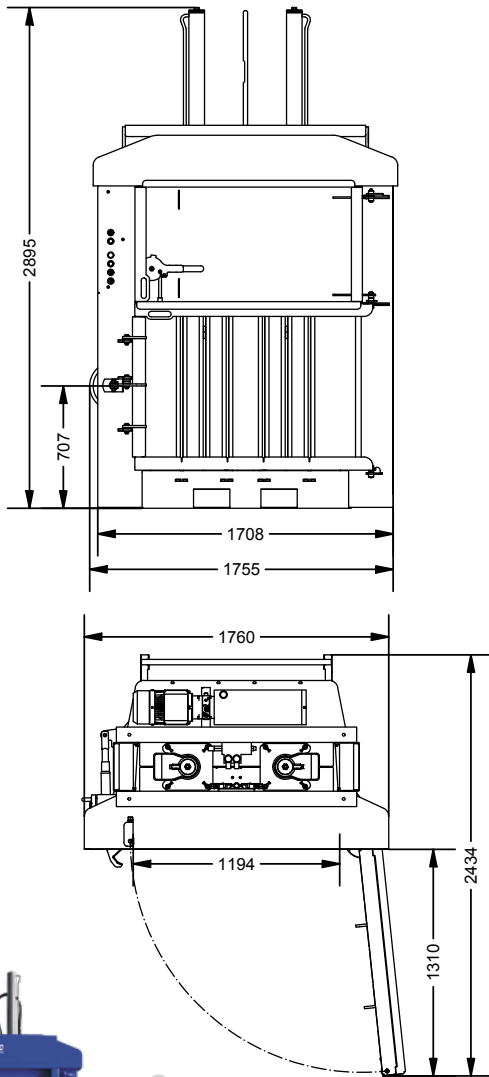

Size Comparison



**Bale Weight**  
Up to 250 Kg



**Pressing Force**  
Up to 16 Ton

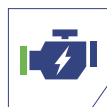

**Motor**  
2.2kW 15A



**Waste Types**  
Cardboard, Plastic  
Film, Paper, E-Waste,  
Cans, LDPE Film ...

